



Q1 2022 TRADING UPDATE

Henrik Badin, CEO Vow ASA
Oslo, 5 May 2022

VOW

DISCLAIMER

This presentation has been prepared by the management of Vow ASA using commercially reasonable efforts to provide estimates and information about the company and prospective new markets.

The presentation includes and is based, inter alia, on forward-looking information and statements that are subject to risks and uncertainties.

In addition, important factors that could cause actual results to differ materially from those expectations include, among others, economic and market conditions in the geographic areas and industries that are or will be major markets for Vow's businesses, market acceptance of new products and services, changes in governmental regulations, interest rates, fluctuations in currency exchange rates and such other factors as may be discussed from time to time in the Presentation.

Vow ASA is making no representation or warranty, expressed or implied, as to the accuracy, reliability or completeness of the information contained in the Presentation, and neither Vow ASA nor any of its directors, officers or employees will have any liability to you or any other persons resulting from your use of the information in the Presentation.

ABOUT US

- › Provider of world leading technologies to **eliminate pollution**, enhance **circular economy** and mitigate **climate change**
- › Offering **patented unique solutions** that turn waste and biomass into **CO2 neutral** energy, **decarbonised** energy, **low-carbon** fuels and **biocarbon**
- › **Proven ability** to continually **develop and deliver** technology and equipment for complex **industry scale solutions** and applications, in close **co-operation with customers**
- › **Strong backlog** of orders and **large installed base** for leading players in a wide range of industries, providing **recurring business**



WELL ESTABLISHED AND WITH PROVEN DELIVERY MODEL



¹ Of which 290 systems are installed on 130 cruise ships, 60 systems within landbased, waste and biomass valorisation, 100 systems with food processing and 4000+ CH Evensen systems

THE CORE OF OUR VALUE PROPOSITION

We aspire to deliver excellence – over and over again

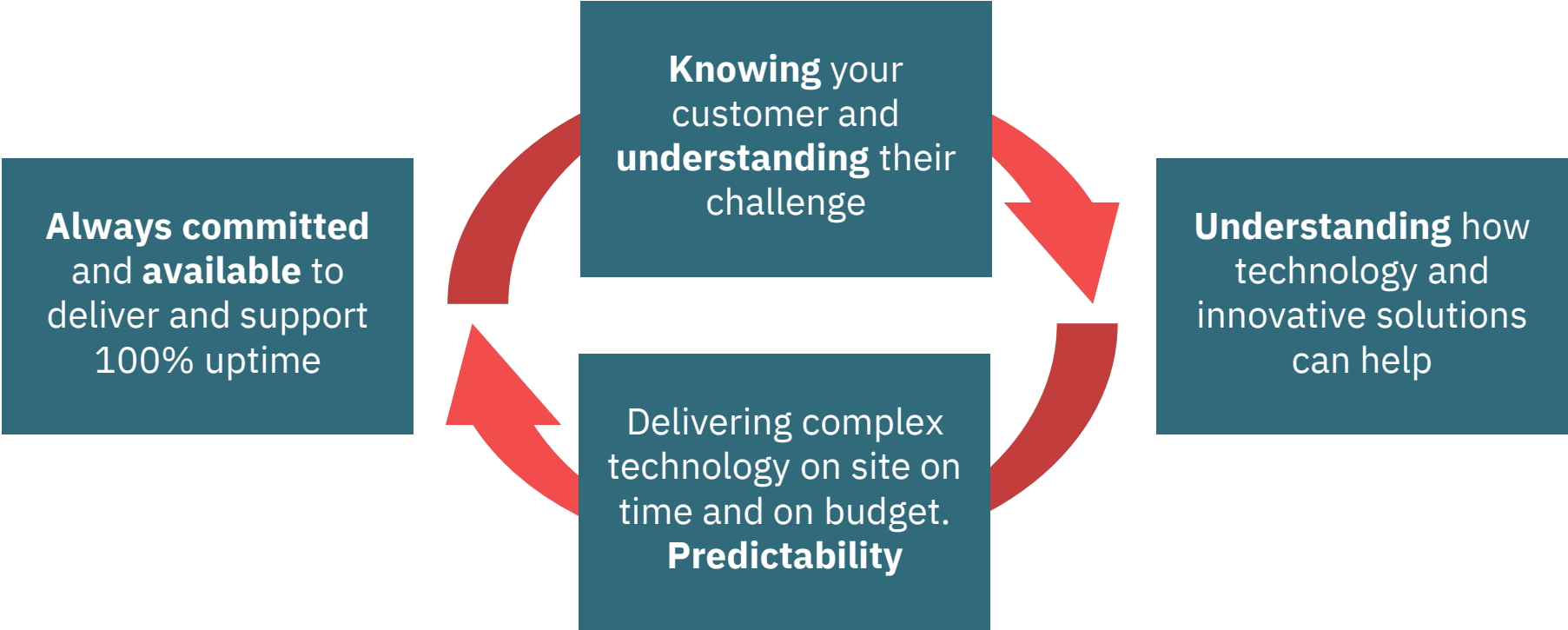



FINANCIAL AND OPERATIONAL HEADLINES

VOW

KEY TAKEAWAYS

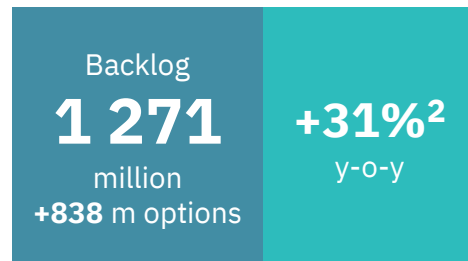

- › Total **order backlog** increased 31% year-over-year to an estimated **2.1 billion** at the time of reporting
- › **Revenue** continues to rise, Q1 22 **nearly doubled** year-over-year to **183 million**, supported by strong order backlog (C.H. Evensen not included)
- › Improved margins proof of efficient delivery model. EBITDA **more than doubled** to **23.6 million**
- › Published **2021 ESG report**, ambition to become **net-zero by 2025** for Scope 1 and Scope 2 emissions
- › Further strengthening foothold and capacities in **landbased** through acquisition of C.H. Evensen Industrioowner. **Cruise** industry is returning to normal, increasing bidding activity for newbuilds and contracts secured

All amounts in NOK

¹ Before non-recurring items of NOK 1.9 million in the first quarter of 2022, primarily related to the acquisition of C.H. Evensen

² Year-over-year (YoY). Backlog as of 5 May 2022. Backlog includes C.H. Evensen

KEY FINANCIALS | GROUP

By quarter

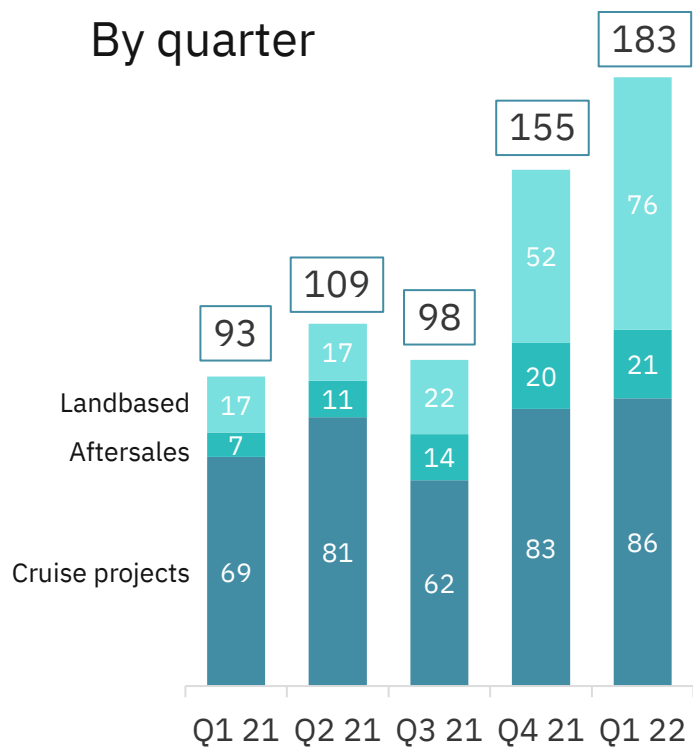

Revenues
In NOK million

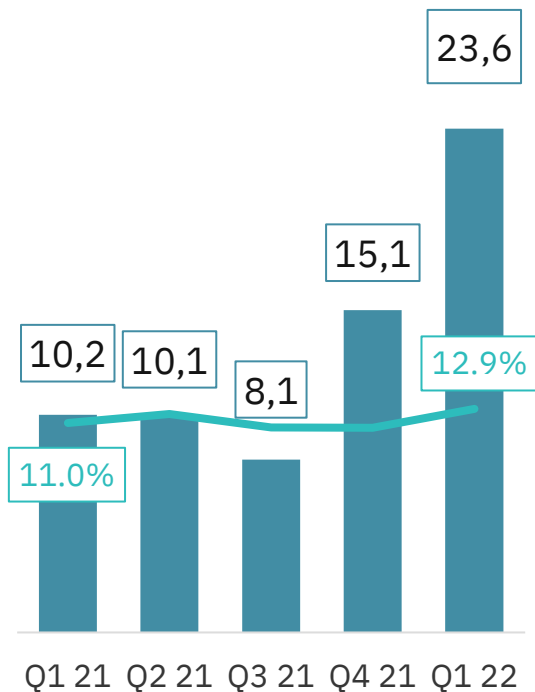

EBITDA and margin
In NOK million and
% before non-recurring items

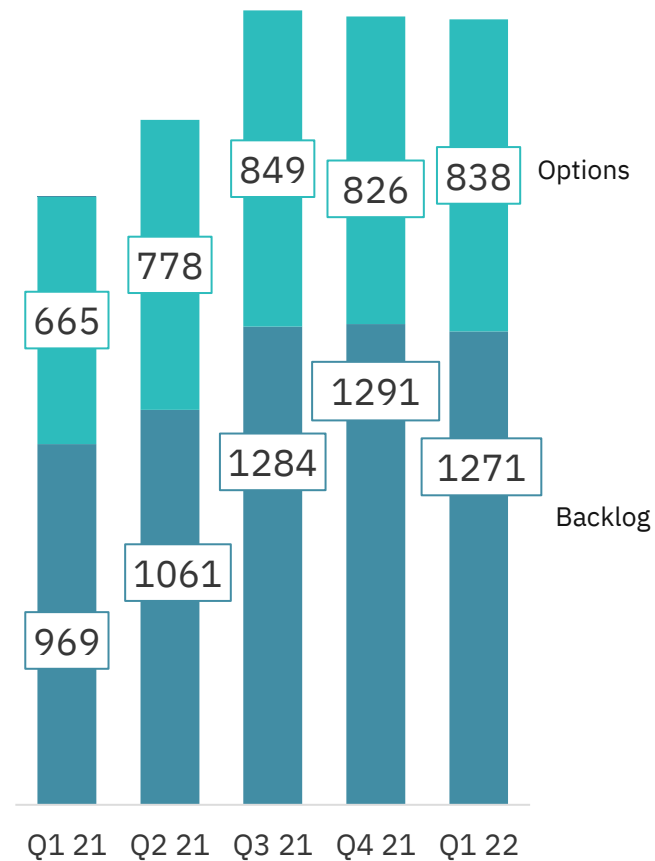

Order backlog and options
In NOK million
Including contracts awarded to date

Q1: PROJECTS | CRUISE

- › Solid progress in revenues and profits. Revenues increased 26% and EBITDA improved 17% year-over-year
- › Strong performance by the team, streamlining deliveries and efficiency effects from replications
- › Order backlog at comfortable levels. Confirmed contracts and options provide visibility well into 2025/26

86.3 million
revenues in Q1 22

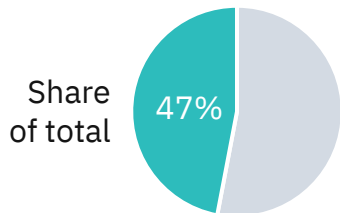

NOK million	Q1 22	Q1 21	FY2021
Revenues	86.3	68.7	294.2
EBITDA	21.1	18.1	67.9
EBITDA margin	24.4%	26.3%	23.1%
Backlog at end of period	944	936	1,012

Floating ceremony of the first large cruise ship built by in China by Shanghai Waigaoqiao Shipbuilding and Fincantieri in a joint venture, featuring **Scanship inside**



Photo: Fincantieri on LinkedIn

CRUISE IS BACK

- Great momentum at Seatrade Cruise Global as operators see all their fleets returning to sea by end of June this year
- Extensive fleet renewal programmes being planned, newbuilds and retrofits, to meet customers and investors' expectations for green shipping
- Scanship secured 1+1 contract for delivery of advanced wastewater purification, food waste processing and garbage handling system to newbuild ships



CRUISE OPERATORS ACTIVELY ENGAGED IN FLEET RENEWAL

High activity and Vow well positioned and with order book far into 2025/26

Year of vessel delivery from yard	Current number of vessels ¹ in cruise industry orderbook, excluding options	Scanship orders for waste management systems	Scanship orders advanced wastewater purification systems
2022	15	10	9
2023	15	6	8
2024	9	8	7
2025	10	8	8
2026	5	4	5
2027	4	4	2
Total	58	40	39

- Vow subsidiary Scanship has earned a reputation as trusted partner
- Cruise operators report plans for retrofitting around 30 ships in the next 1-2 years
- Creating opportunities for Aftersales business

¹ Smaller ships with less than 600 pax capacity is not included in this overview.
Source: Cruise Industry News.



Q1: AFTERSALES | CRUISE

- Cruise operations continued to resume as Covid-19 restrictions ease in key markets
- Revenues tripled year-over-year from very low levels. Still at around half of pre-covid level
- With more newbuilds coming into service, market for Aftersales is growing. Will over time likely surpass previous levels, since Vow's installed base has increased

20.5 million
revenues in Q1 22

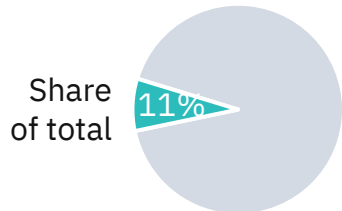

NOK million	Q1 22	Q1 21	FY2021
Revenues	20.5	7.3	51.9
EBITDA	1.0	0.3	0.4
EBITDA margin	4.9%	4.1%	0.7%

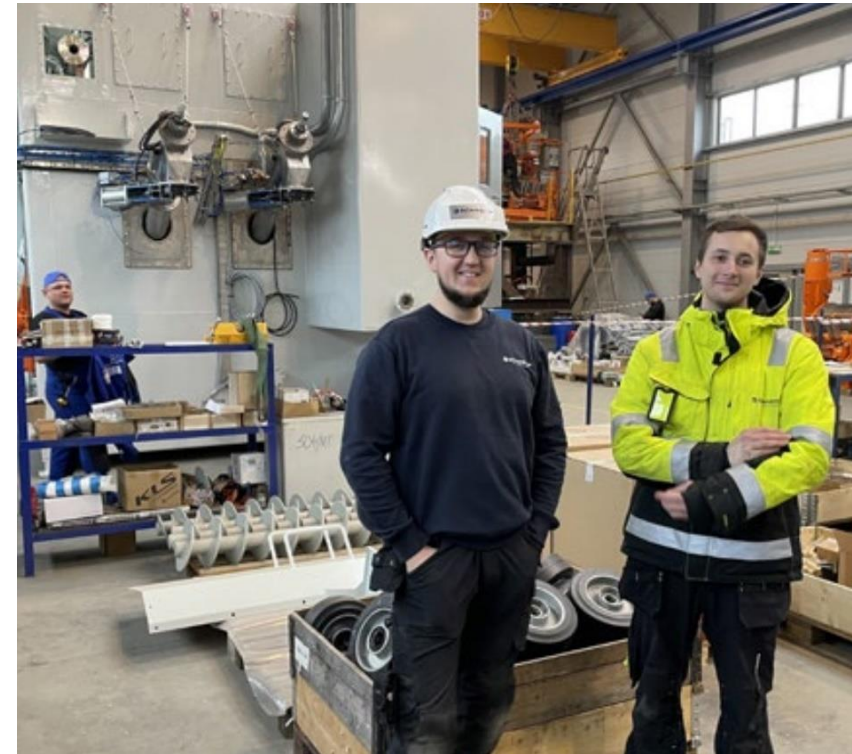

AS SHIPS TAKE TO SEA, DEMAND FOR CHEMICALS, SPARES AND SERVICE REBOUND

- › Covid-19 hit Aftersales hard from Q2 2020
- › Coming out of Q1 2022, activity is climbing steeply towards a full fleet deployment
- › As cruise ships are returning to sea, demand for chemicals, spares and service support increase
- › Number of active ships with Scanship equipment onboard has increased from 70 at end of Q4 21 to 113 by 1 May 2022
- › Scanship’s installed based has increased by 13% during 2020-21

Number of cruise ships in service
At end of period

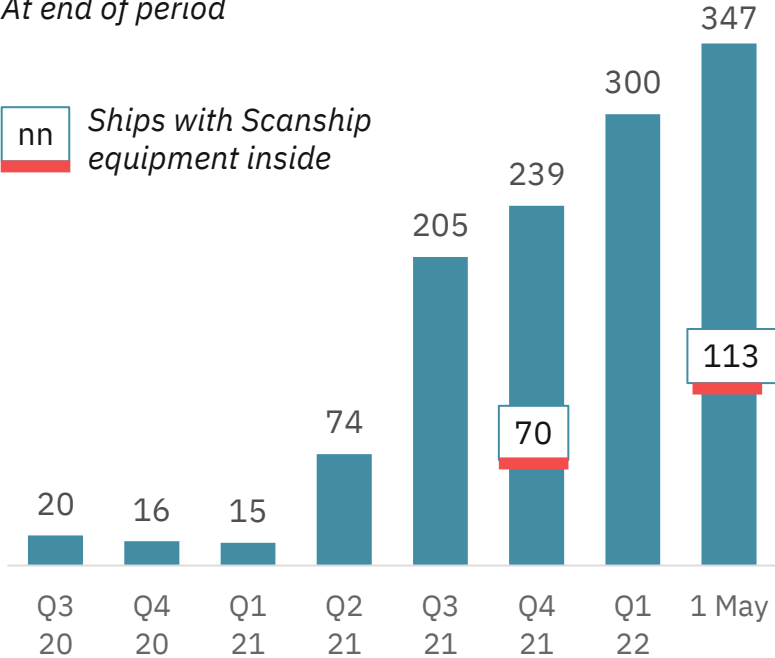

Source: Cruise Industry News

Q1: LANDBASED

- Significant growth in revenues and profits, with Vow Green Metal's Follum project representing a large share
- Production of equipment for Follum continues as planned for delivery later this year
- Ongoing studies to qualify pyrolysis gas for European gas grid, and biocoal as replacement for fossil coal in non-ferrous metal production processes could speed up roll-out of Vow technology

75.7 million
revenues in Q1 22

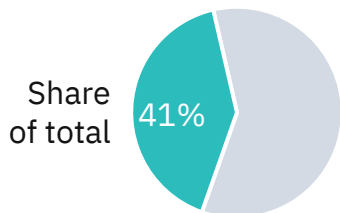

NOK million	Q1 22	Q1 21	FY2021
Revenues	75.7	16.8	108.0
EBITDA	8.5	-4.4	-7.1
EBITDA margin	11.2%	-26.2%	-6.5%
Backlog ¹ at end of period	327	33	279

EBITDA before non-recurring items

¹Including C.H. Evensen order backlog of 100 million

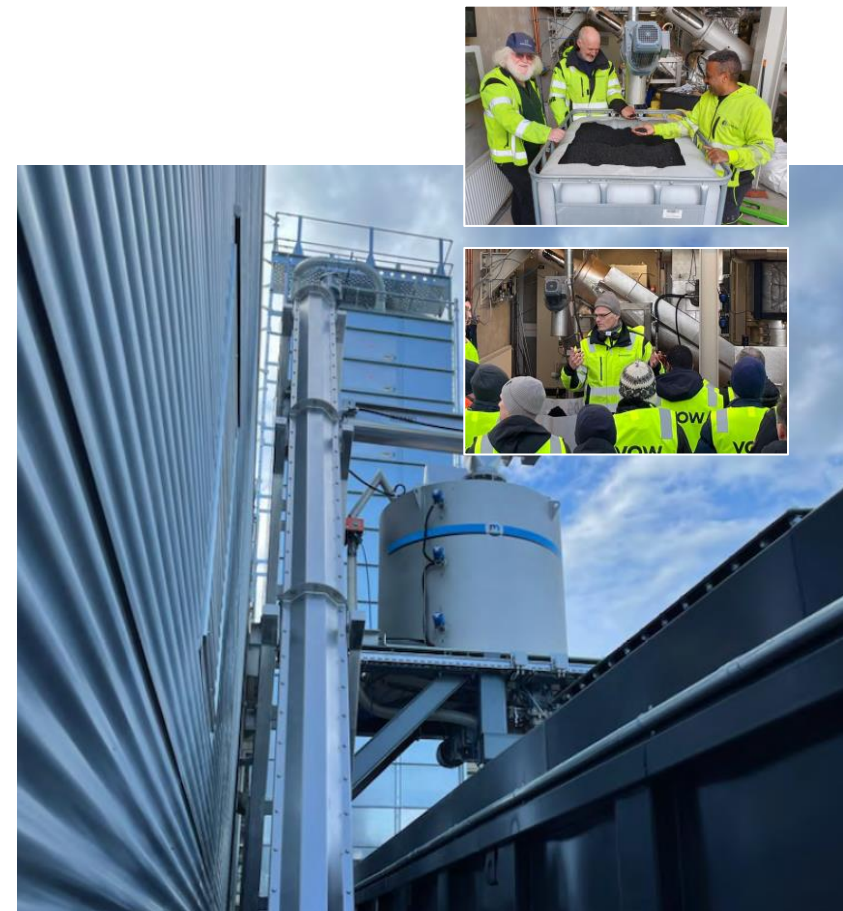



THE C.H. EVENSEN ACQUISITION

VOW

CHE ACQUISITION

- Further strengthening foothold and capacities in landbased industry verticals
- C.H. Evensen has 40 employees
Culturally well aligned with rest of Vow
- Pre-audit 57 million in total sales for 2021
EBITDA margin of 10.4%
- Purchased for 50 million, settled in cash and 25 million in seller's credit (vendor note) payable 14 months after closing
- Seller can elect to settle the note with Vow shares at a price of NOK 25 per share



LARGE AND LOYAL CUSTOMER BASE

- C.H. Evensen established in 1937, ranking as a leader in its field
- Trusted partner and supplier of technology for high-temperature industrial processes, with increasing focus on energy efficiency and non-fossil solutions
- Installed base of more than 4,200 systems worldwide and a loyal customer base, featuring renowned blue-chip names
- Recently signed contracts with Otto Lehmann and undisclosed metal producer, bringing total order backlog to more than 100 million¹

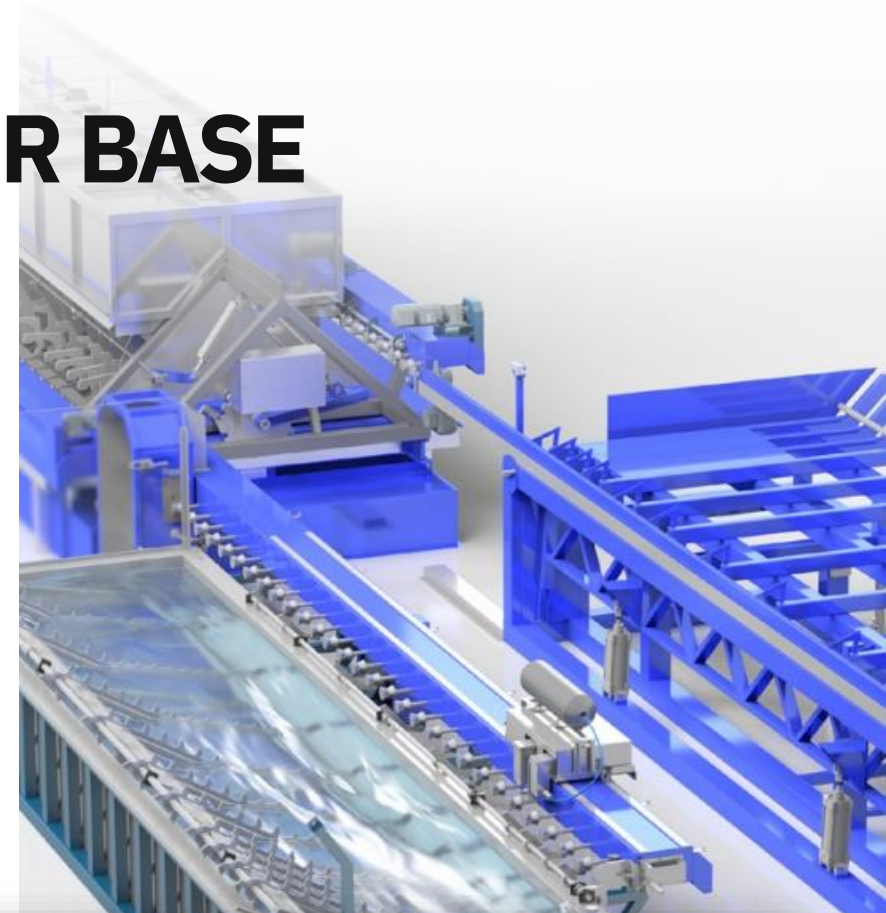

RECSILICON



voestalpine
EINEN SCHRITT VORAUSS.

NEUMAN
ALUMINIUM
RAUFOSS

ALUDYNE

¹ Not including large scale pyrolysis reactor ordered by Vow

COMPLEMENTARY TECHNOLOGIES

Microwave assisted
pyrolysis (MAP)



Well suited for processing of organic waste and production of clean energy, for instance on board a cruise ship

Biogreen



For production of sophisticated and advanced biocarbon, needed for instance by the metallurgical and advanced materials industries

C.H. Evensen reactor

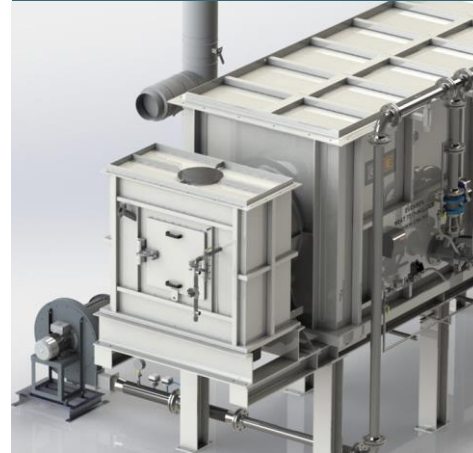

For processing large volumes of biomass, such as forestry waste and waste wood, and production of clean energy and biochar

CHE + Biogreen



Two-step process with several Biogreen units connected to each Evensen reactor to further multiply output

INTRODUCING THE CHE REACTOR TO MEET INCREASED DEMAND

- With growing demand from industry customers to decarbonise, recycle carbon, and to secure access to reliable and locally produced CO₂ neutral energy, Vow decided to start building a large-scale pyrolysis reactor for production of biocarbon and syngas
- The reactor is built by C.H. Evensen and will be completed and available by the end of 2022
- The CHE Reactor is based on well-known and proven technology. It is a combined reactor, in the sense that the energy required to fuel and run the process comes either from the feedstock itself or from electricity
- In an application based on forestry residues, the reactor will produce up to 100 GWh of syngas and 10,000 tonnes of biocarbon per year

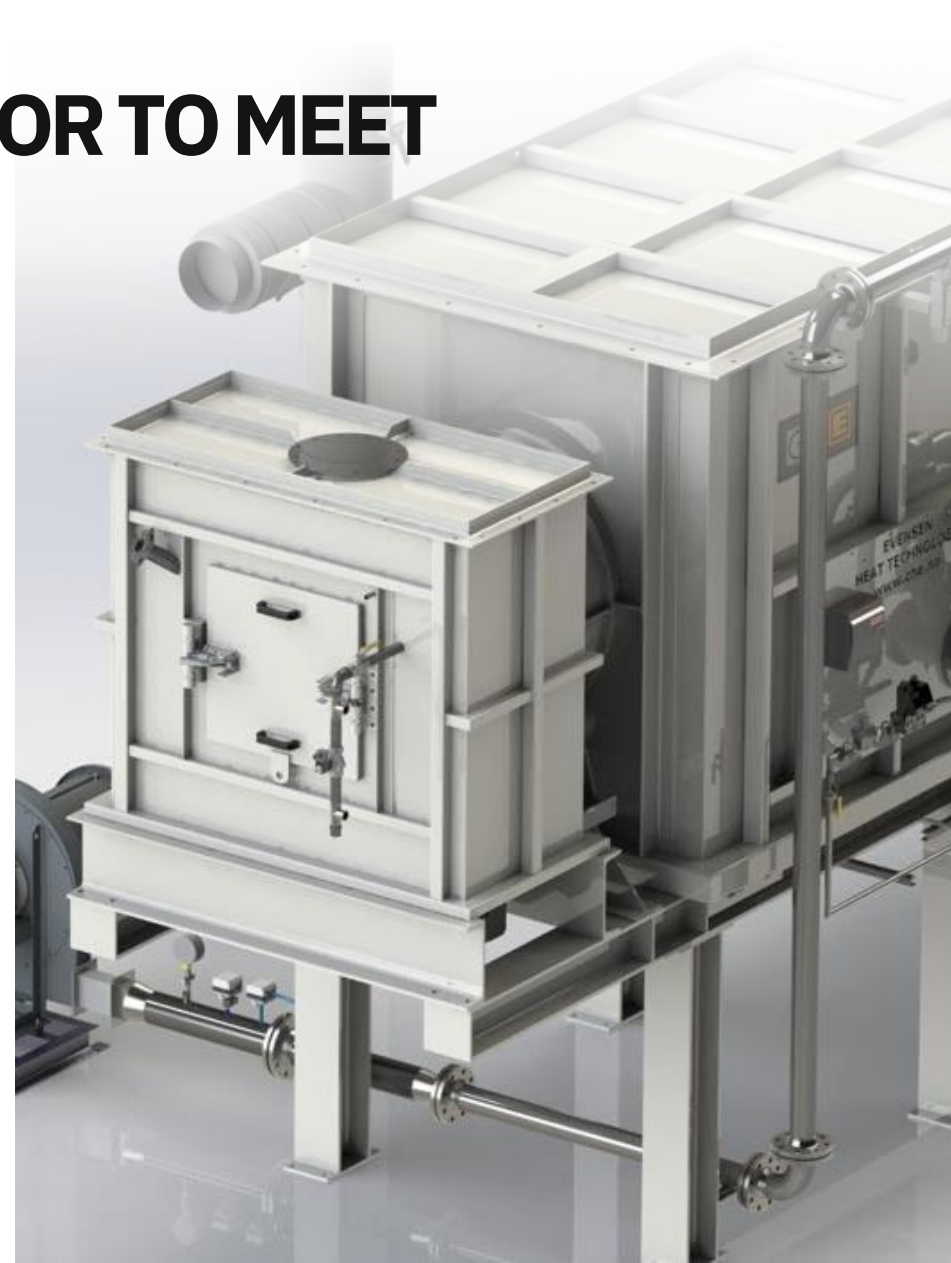



MARKET TRENDS AND OUTLOOK

VOW

WHAT DRIVES DEMAND FOR OUR TECHNOLOGIES



Industry push for decarbonising



Economic realities



Circular economy



Government policies and regulation



A new world order

Energy security
Self sufficiency

FOR OUR CUSTOMERS THESE TRENDS ARE REFLECTED IN RISING COSTS AND CARBON TAX

Cost of CO2 emissions

EU CO2 emission cost (ETS) 2016-2022, and estimate 2030

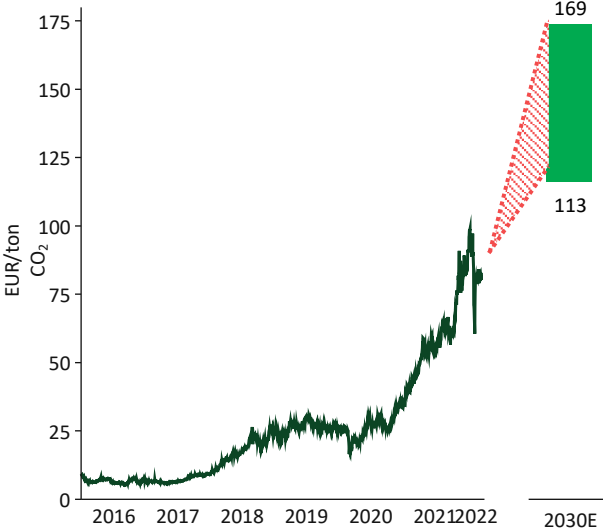

Price for metallurgical coking coal

Price for met coke 65-66% China included EU CO2 emission cost (S&P Global Platts 2022).

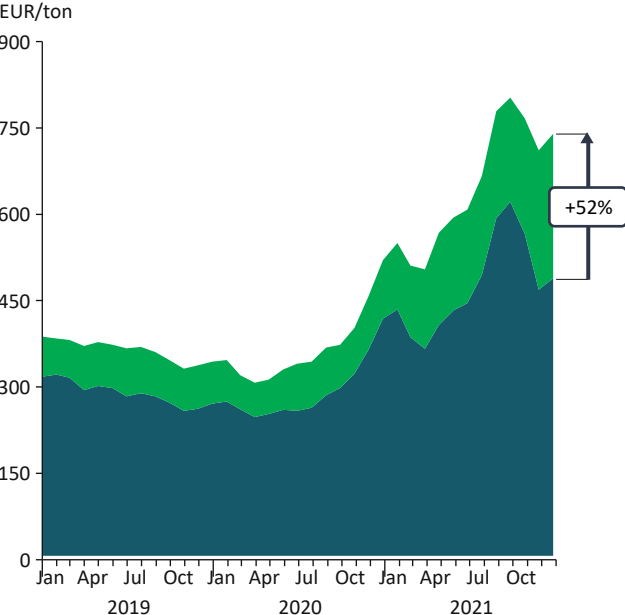

Price for natural gas in EU

Price for Dutch TTF natural gas. Five times higher than in most of 2019-2020, and now very volatile

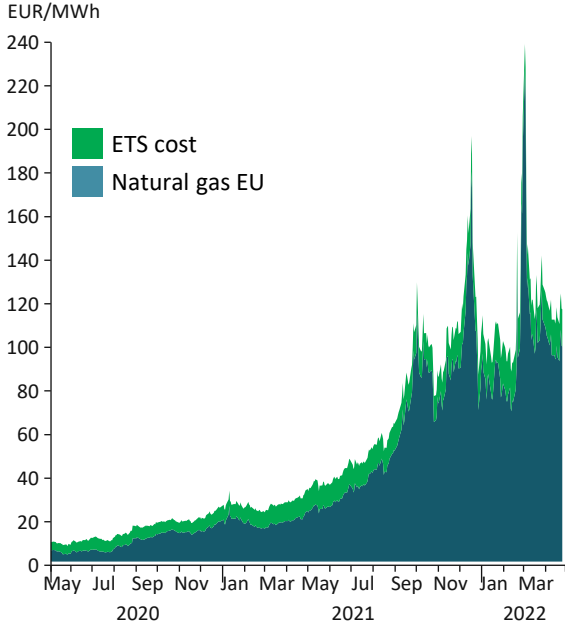

INDUSTRY USE MORE THAN 1,000 TWH NATURAL GAS TODAY

Pyrolysis gas is becoming available as a solution for industry seeking self-sufficiency and carbon neutrality in energy supplies

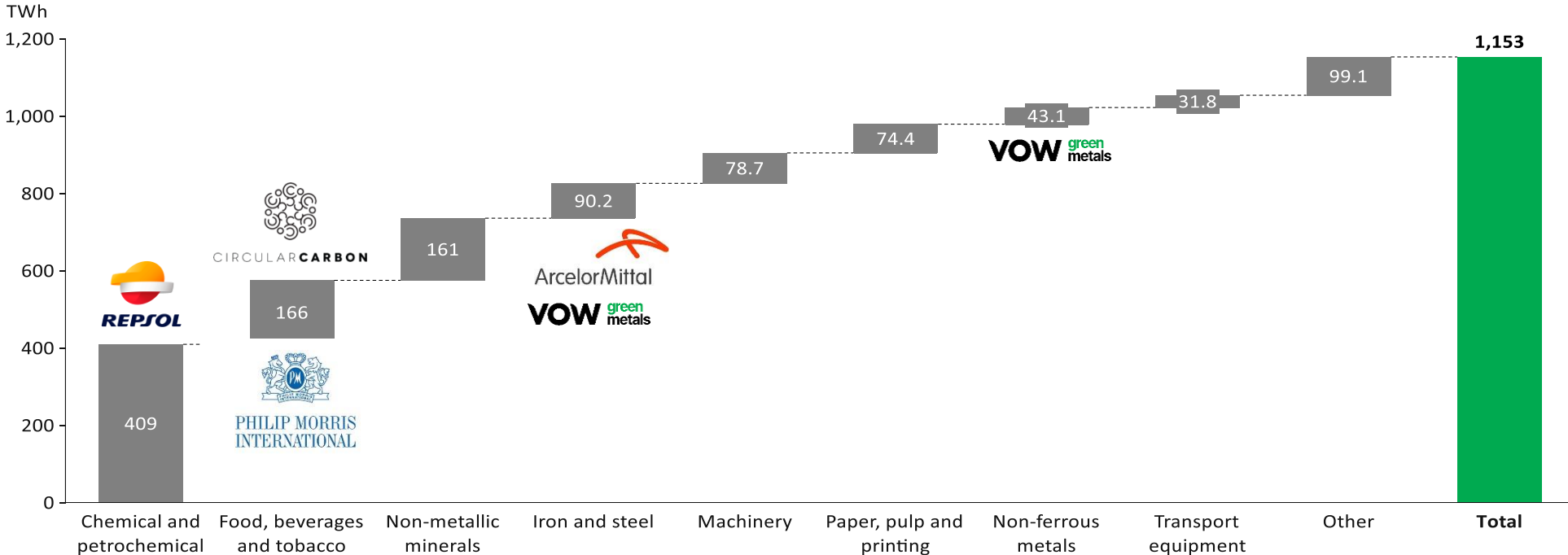

Source: Eurostat - Supply, transformation and consumption of gas, EU 2019, 279 kWh/GJ

UNLOCKING A NEW MARKET FOR PYROGAS

Qualifying pyrogas for the European gas grid, helping countries to decarbonise and become more self-sufficient

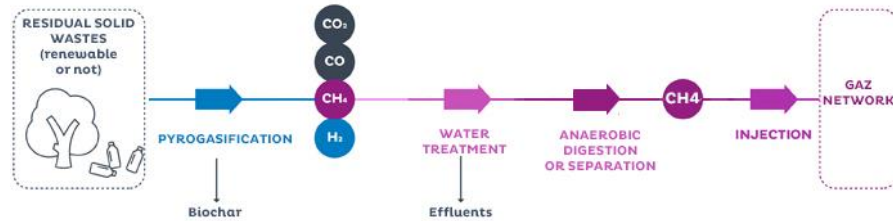

GRTgaz

Europe's second largest gas distributor

“Pyrogasification for injection has reached a level of technological maturity that means we can envisage the construction of the first industrial facilities in France from 2023.”

“By 2030, the network operators’ forecast assessment based on the goals set out in the regional plans shows that pyrogasification could represent 6 TWh of injected gas per year, i.e. up to 1 million tonnes of CO₂ avoided.”

“This technology of the future will thus contribute to achieving 100% renewable or low-carbon gas consumption in France by 2050.”

Overview of pyrogasification for injection in France

More than ten commercial projects and gas production demonstrators in France have already been made public.

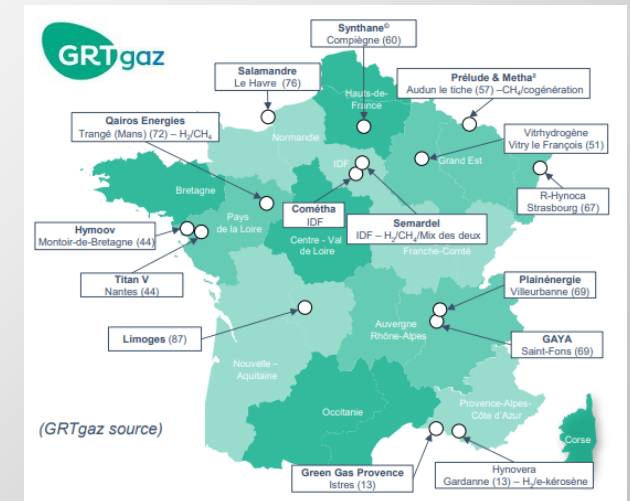

THE 50,000-TONNES BIOCARBON PROJECT

Equivalent to 5x initial production capacity at Follum project and **EUR 85-100 million** worth of Vow technology
A **large-scale project in the circular economy**, feeding a leading European non-ferrous metal producer with biocarbon

Sustainable feedstock

- › Forestry wood mass
- › Biomass waste streams
- › Wood materials



50,000 tonnes

CO₂ neutral biocarbon,
replacing the equivalent of

EUR 37 million
of fossil coking coke

300 GWh

CO₂ neutral syngas,
replacing the equivalent of

EUR 32 million
in fossil natural gas

Q1 SUMMARY

- › All time high financial results
 - Revenue nearly doubled year-over-year to 183 million
 - EBITDA more than doubled to 23.6 million, proving efficient delivery model
- › Pyrolysis emerging as preferred solution for industrial scale production of renewable gas for grid and recycling of carbon materials
- › Further strengthening foothold and capacities in landbased through acquisition of C.H. Evensen Industriovner
- › Cruise industry is returning to normal, increasing bidding activity for newbuilds and contract secured
- › Total order backlog remained robust and comfortable at 2.1 billion with orders well into 2024/25. Revenue target for 2022 maintained





Q1 2022 TRADING UPDATE

VOW